

CP-302

Issued May 2007 • Index No. DC/13

**MIG Welding
Power Source** 

Quick Specs

Industrial/Heavy Industrial Applications

Light Fabrication
Automotive
Furniture
Agricultural
Truck Body/Metal Fabrication
Small Equipment Manufacturing

Processes

MIG (GMAW)
Flux Cored (FCAW)

Input Power 3-Phase Power

Rated Output 300 A at 32 V, 100% Duty Cycle
390 A at 32 V, 60% Duty Cycle

Max. Open-Circuit Voltage 14-44

Weight 332 lb (151 kg)

The Power of Blue.®

CP-302 MIGRunner™ comes complete in one box. See page 4 for details.

Adjustable weld stabilizer (high-low inductance) provides the flexibility to produce the optimal arc characteristics. Use the high stabilizer setting for stainless steel and low setting for mild steel and aluminum.

Solid-state weld contactor provides longevity to match the ultra-durable and reliable reputation of the CP series.

115 VAC duplex receptacle provides 15 amps of auxiliary power.

14-pin receptacle provides quick, direct connection to wire feeders and accessories.

Presettable welding voltage with voltmeter allows you to easily set weld output before welding.

Large analog volt and ammeters for easy viewing.

Power efficient which gives exceptional value and return on your investment.

Simple control panel with just one control adjustment.

Lower panel cover protects output connections from harsh welding environments.



TRUE BLUE
3YR. WARRANTY

Welder is warranted for 3 years, parts and labor. Original main power rectified parts are warranted for 5 years.

MADE IN USA
APPLETON, WI 



Miller Electric Mfg. Co.
An Illinois Tool Works Company
1635 West Spencer Street
Appleton, WI 54914 USA

International Headquarters
Phone: 920-735-4505
USA FAX: 920-735-4134
Canadian FAX: 920-735-4169
International FAX: 920-735-4125

Web Site
www.MillerWelds.com



Specifications (Subject to change without notice.)



Rated Output	Open-Circuit Voltage	Amps Input at Rated Output, Three-Phase, 60 Hz						Dimensions	Net Weight
		200 V	230 V	460 V	575 V	KVA	KW		
300 A at 32 V, 100% Duty Cycle	14-44	38	33	16.5	13.0	13.1	12.3	H: 30 in (762 mm) including lift eye W: 23 in (585 mm) D: 30-1/2 in (775 mm) including strain relief	332 lb (151 kg)
390 A at 32 V, 60% Duty Cycle		1.1*	.95*	.48*	.38*	.38*	.32*		

Conforms with NEMA EW 1, "Electric Arc Welding Power Sources", Class I (100).

*While idling.

Certified to both the Canadian and U.S. Standards for welding equipment.

Control Panel

1. Ammeter
2. Voltmeter
3. Power Switch
4. Pilot Light
5. Preset Indicator Light
6. Voltage Control

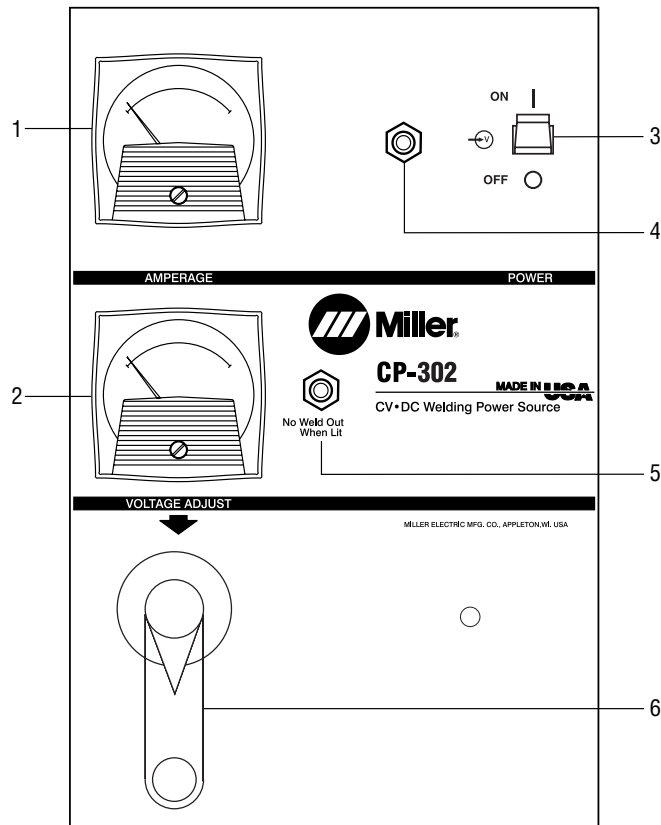

Performance Data

DUTY CYCLE CHART

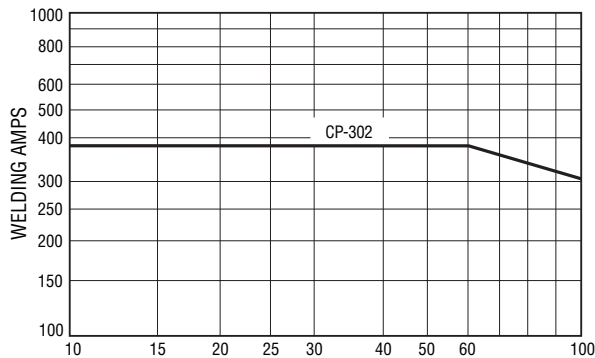

VOLT/AMP CURVE

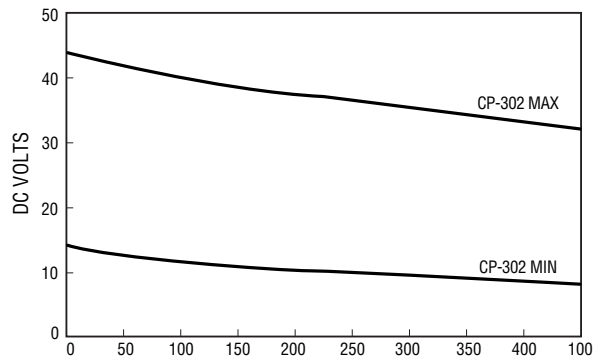

Genuine Miller Accessories



Industrial MIG Kit #195 197

Includes 15 ft (4.6 m), 2/0 power cable and work lead with clamp, regulator/flow meter with 15 ft (4.6 m) gas hose, 15 ft (4.6 m) MIG gun and consumable kit.



Standard Running Gear #042 886

The large 10 in (254 mm) rear wheels and 5 in (127 mm) front casters on this running gear provide excellent mobility on the shop floor, making it easier to move the power source. Very easy to install. Handles double as weld cable holder.

Standard Cylinder Rack #042 887

Holds two cylinders. Only installs on Standard Running Gear.

Wire Feeders



22A #193 066

Lightweight, 24 VAC constant-speed semi-automatic wire feeder, best suited for small diameter wires. Accommodates up to a 60 lb (27.2 kg) spool of welding wire when using optional wire reel assembly. Comes with FREE Bernard® Q™-Gun! See Lit. Index No. M/11.0.



70 Series

Single Wire Model

S-74S #195 057

Dual Wire Model

D-74S #195 060

Heavy-duty, industrial, constant-speed 24 VAC semiautomatic wire feeders in single and dual models, with available digital meters. Ideal for high-duty-cycle MIG welding (GMAW) and Flux Cored welding (FCAW). Accommodates a wide variety of wire sizes and types. Comes with FREE Bernard® Q™-Gun! Dual wire feeder model includes two FREE Q-Guns. See Lit. Index No. M/3.0.

Extension Cables for 14-Pin Plugs to 14-Pin Sockets

#122 973 25 ft (7.6 m)

#122 974 50 ft (15.2 m)

#122 975 75 ft (22.8 m)



Spoolmatic® 30A #130 831

A 1-lb, air-cooled spool gun that extends the weld process range by adding a handy portable system for small wire MIG. Rated 200 A at 100% duty cycle. Includes 30 ft (9.1 m) cable assembly. (WC-24 #137 549 for 14-pin.)



WC-24 Weld Control #137 549

Packaged in a compact, lightweight, non-metallic enclosure, the WC-24 easily mounts directly on the power source.

It's designed for use with Miller CV power sources supplying 24 VAC and 14-pin receptacles. The control includes a board-mounted potentiometer which can alter the drive motor acceleration rate to optimize arc starting performance.

CP-302 MIGRunner Components

CP-302 MIGRunner™

#907 050 200/230/460 V

#907 073 575 V

Comes Complete With:

- CP-302 power source
- 22A wire feeder
- Bernard® Q™-Gun 15 ft (4.6 m)
- .035/.045 in contact tips
- .035/.045 in reversible drive rolls
- Regulator/flow gauge with gas hose
- Work cable and power cord
- Factory-installed running gear/cylinder rack



Ordering Information

Equipment and Options	Stock No.	Description	Qty.	Price
CP-302	#903 786	200/230/460 V, 60 Hz		
	#903 521	575 V, 60 Hz		
CP-302 MIGRunner	#907 050	200/230/460 V, 60 Hz. See above for package components		
Wire Feeders				
22A	#193 066	See Lit. Index No. M/11.0		
70 Series	#195 057	S-74S. See Lit. Index No. M/3.0		
	#195 060	D-74S. See Lit. Index No. M/3.0		
Extension Cables for 14-Pin Plugs to 14-Pin Sockets	#122 973	25 ft (7.6 m)		
	#122 974	50 ft (15.2 m)		
	#122 975	75 ft (22.8 m)		
Spoolmatic® 30A	#130 831	1-lb air-cooled spool gun, 200 A at 100% duty cycle, includes 30 ft (9.1 m) cable assembly		
WC-24 Weld Control	#137 549			
Guns				
Bernard® Gun				
Consumables				
Accessories				
Industrial MIG Kit	#195 197	Includes 15 ft (4.6 m), 2/0 power cable and work lead with clamp, regulator/flow meter with 15 ft (4.6 m) gas hose, 15 ft (4.6 m) MIG gun and consumable kit		
Standard Running Gear	#042 886			
Standard Cylinder Rack	#042 887			

Date:

Total Quoted Price:



Distributed by: